

TYPICAL CONFIGURATIONS SD700
Pump Control Macro – single VSD with Jockey Pump

S/W version 1.410

Created: **M.Duncan**
Position: **Sales & Marketing Director**
Date: **17/06/09**

Reviewed: **B.Sheridan**
Position: **Technical Director**
Date: **19/06/09**

TYPICAL CONFIGURATIONS SD700

Pump control macro for single VSD operation with jockey pump control. Single system setpoint from keypad. Pressure feedback via analogue input 1.

Manual/Off/Auto control, high pressure switch, sleep on speed. Optional flow switch and pulse flow meter.

1.- Configuration Parameters

SCREEN	DESCRIPTION	DISPLAY	VALUE (DEFAULT)
G1: MENU OPTIONS			
4	Language	LANGUA=	ENGLISH
5	Initialise	INITIALISE=	(0) No initialise
7	Macro selection	PROG=	(STANDARD) Set to PUMPS
G2: NAME PLATE			
1	Motor rated current	MTR CUR=	A (* model dependent) Enter motor FLC
2	Motor rated voltage	MTR VOL=	(400V) Enter motor VOLTAGE
3	Motor power	MTR PWR=	kW (* model dependent) Enter motor kW
4	Motor speed	MTR RPM=	(1483) Enter motor RPM
5	Motor power factor	MTR PFA=	(0.91) Enter motor p.f
6	Motor frequency	MTR FRQ=	(50Hz) Enter motor FREQUENCY
7	Motor cooling	MTR COOLN=	(63%)
G4: INPUTS			
S4.1: DIGITALS			
5	Programming of digital input 1	DIGITL IN 1=	(NO USE) set to 50 PMP START/STP. N.O contact
6	Programming of digital input 2	DIGITL IN 2=	(NO USE) set to 57 MAN PROTstart. N.O contact
7	Programming of digital input 3	DIGITL IN 3=	(NO USE) set to 58 HI PRESS FLT. N.C contact
8	Programming of digital input 4	DIGITL IN 4=	(NO USE) set to 61 FLOW SWITCH. N.C contact
9	Programming of digital input 5	DIGITL IN 5=	(NO USE) set to 51 FLOW PULSE
10	Programming of digital input 6	DIGITL IN6=	(NO USE) set to desired pump function
S4.2: ANLG INPUT1			
1	Selection of pressure sensor	SENSOR 1 ?=	(N) set to Y for pressure sensor
	Sensor configuration	&SENSOR CONFIG	* only visible when screen 1 is set to Y
2	Sensor units	SENSOR 1=	(l/s) select pressure sensor units e.g Bar
3	Analogue input format	AIN1 FORMAT=	(V) select V (0-10V) or mA (4-20mA)
4	Minimum signal value	INmin1=	(+0.0V) set to minimum signal level V or mA
5	Sensor minimum value	Smi1=	(+0.0l/s) set to minimum value of sensor e.g 0 Bar
6	Maximum signal value	INmax1=	(+10.0V) set to maximum signal level V or mA
7	Sensor maximum value	Sma1=	(10.0l/s) set to maximum value of sensor e.g 10 Bar
S4.4: PULSE INPUT			
1	Pulse meter units	Sensor U=	(l/s) select pulse meter units e.g m3/h
2	Pulse meter configuration	Pls/s =	(100l/s) set flow rate per pulse output
3	Pulse meter max range	M Rng =	(1000l/s) set to max range of pulse meter
G5: RATES ACC/DEC			
1	Acceleration rate	ACC1=	(3%/s) adjust to at least 20%/s so not to interfere with PID performance
2	Deceleration rate	DECEL1=	(3%/s) adjust to at least 20%/s so not to interfere with PID performance
G8: OUTPUTS			
S8.1: DGT OUTPUT			
1	Selection of relay 1 function	SEL RELAY 1=	(2, NO FAULTS) set to 29, JOCKEY PUMP
G10: LIMITS			
1	Minimum speed limit	MIN SP1=	(+0.00%) adjust to suit pump/motor
2	Maximum speed limit	MAX SP1=	(+100%) adjust to suit pump/motor
5	Current limit	I LIMIT=	A (* model dependent) adjust to motor FLC

G25: PUMP			
S25.1: SYS SETPNT			
1	Pump control mode	CONTROL MODE=	(1, PUMP) set to MANUAL for system checks. Set to PUMP for auto operation
2	Manual speed reference	MAN REF1=	(LOCAL) select source for manual speed reference
3	Manual speed	MAN SPD=	(+0.0%) set running speed for manual control
5	Local pressure setpoint for PID	SETPT1=	(0.0Bar) adjust to desired system setpoint pressure
S25.2: PID TUNING			
1	PID setpoint selection	PID SETP=	(LOCAL) select reference for setpoint
3	PID pressure feedback selection	PID FBK=	(AI2) select source for pressure feedback. Set to AI1.
4	PID proportional gain	PID Kc=	(1.0) adjust proportional gain for PID
5	PID intergral gain	PID It=	(5.0s)
S25.3: START COND			
1	System wake up pressure	LP Pon=	(0.0 Bar) adjust to desired wake up pressure level
S25.4: STOP COND			
1	Sleep delay time	LP T SLP=	(20s) set delay time before drive will go to sleep
2	Sleep speed 1	SLPspd1=	(+40.0%) adjust speed at which drive will go to when using local pressure setpoint 1
30	Go to sleep on start	GO SLEEP MO=	(N) set to Y if requiring drive to sleep instantly upon receiving start command when pressure is greater than wake up pressure.
S25.6: PROTECT			
1	Protection re-start pause delay	PAUSE/DEL=	(0s) set time before restart after protection pause
2	Cavitation protection enable	CAVITATION=	(N) set to Y for cavitation protection
3	Cavitation mode	CAV MODE=	(FAULT) select either FAULT or PAUSE option
4	Cavitation current level	CAV CURR=	(* model dependent). Set cavitation current level
5	Cavitation speed	CAV SPED=	(+100%) adjust speed above which cavitation protection becomes active.
6	Cavitation trip delay time	CAV DELY=	(10s) adjust delay time before drive trips on CAV
7	Enable low pressure trip	ENA LO PRESS=	(N) set to Y for LP trip
8	Low pressure trip level	LO PRE=	(5.0Bar) set low pressure trip level
9	Low pressure trip delay time	Lop DLY=	(10s) adjust delay time before drive trips on LP
12	High pressure mode	HIpr Mo=	(PAUSE) select FAULT or PAUSE option
13	High pressure trip level	HIpre=	(100Bar) HP trip level
14	High pressure trip delay time	HIpr DLY=	(0.0s) adjust delay time before drive trips on HP
S25.7 FILL/STPrp			
2	Pipe fill fixed speed	FILL SP=	(+70%) adjust speed to fill empty pipe
3	Pipe fill pressure level	FILL P=	(2.0Bar) adjust pressure level that indicates pipe is full of water
4	Pipe fill time	FILL TIM=	(15m) adjust max time to run at pipe fill speed
5	PID setpoint ramp	SPT RA=	(1.0Bar/s) adjust ramp rate the PID setpoint increases at up to setpoint pressure level (S25.1.1)

Denotes minimum necessary adjustments

All other listed parameters provide optional control/protection

TYPICAL CONFIGURATIONS SD700

2.- Control terminal connections.

Digital and analogue inputs

- Terminals 1 / 2 : Auto/Off/Manual switch. Auto pump str/stp (NO contact)
- Terminals 1 / 3 : Auto/Off/Manual switch. Protected manual str/stp (NO contact)
- Terminals 1 / 4 : High Pressure switch (NC contact – open = high pressure)
- Terminals 1 / 5 : Optional, flow switch (NO contact – open = no flow)
- Terminals 1 / 6 : Optional, pulse flow meter (reed switch type shown)
- Terminals 20 / 10 : Analogue input 4-20mA.

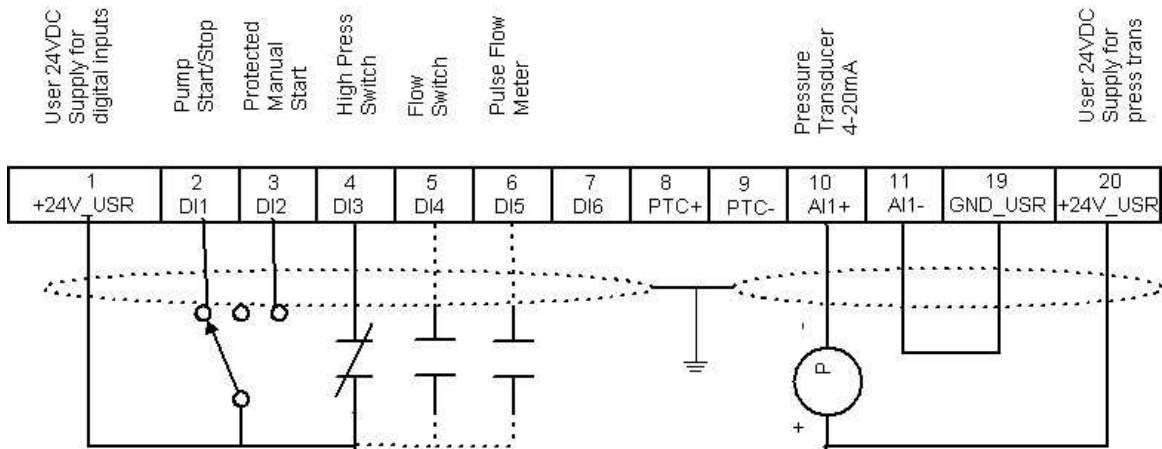

NOTE: the remote control cables must be screened

Digital outputs

- Terminals 26 / 27 : Output to control Jockey Pump.

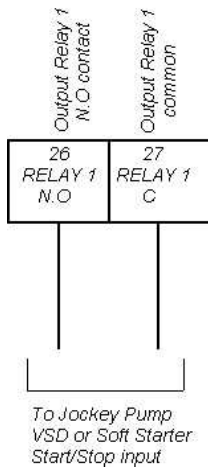

3. – Notes for easy parameter setup

- Complete all field wiring first before programming the drive.
- Ensure “Pump Start/Stop” input (T2) and “Manual Protected Start/Stop” input (T3) are open before programming to prevent accidental starting of the drive and motor.

G1 OPTIONS MENU

- Set the drive into English by programming screen **G1.4 LANGUA** to “ENGLISH”
- Set the drive into pump control macro by programming screen **G1.7 PROG** to “PUMPS” (a small “p” will appear in the top left hand corner of the display confirming that the SD700 is in pump macro mode)

G2 NAME PLATE

- Enter all motor nameplate details into screen group **G2 NAME PLATE**

G4 INPUTS

- Program the digital inputs for “PMP START/STP”, “MAN PROTECTED START”, “HI PRESS FLT” as follows:
 - **S4.1.5 DIGITL IN 1** = 50 PMP START/STP
 - **S4.1.6 DIGITL IN 2** = 57 MAN PROTstart
 - **S4.1.7 DIGITL IN 3** = 58 HI PRESS FLT
 - S4.1.8 DIGITL IN 4 = 61 FLOW SWITCH (optional)
 - S4.1.9 DIGITL IN 5 = 51 FLOW PULSE (optional)

Note: You must program “PMP START/STP” digital input first before you can program the remaining digital inputs. It is only possible to program the digital inputs from options 24, 50 – 70.

- When setting up analogue input 1 as a pressure transducer feedback, it is possible to set the input to represent a sensor in true engineering units. Once the engineering units have been set, all values in screen group **G25 PUMP** relating to pressure, will display in the selected engineering units.
- Configure analogue input 1 for a pressure transducer by setting screen **S4.2.1 SENSOR 1 ?** to Y(es)
- Select the correct engineering units of the pressure transducer in screen **S4.2.2 SENSOR 1**
- Set the pressure transducer output format in screen **S4.2.3 AIN1 FORMAT**. A pressure transducer is typically 4-20mA so in this case set this screen to mA.
- Set the minimum signal level of the pressure transducer in screen **S4.2.4 INmin1** i.e 4mA for a 4-20mA input.
- Set the minimum engineering units of the pressure transducer when it outputs the minimum signal level in screen **S4.2.5 Smin1** e.g 0kPa for 4mA input.
- Set the maximum signal level of the pressure transducer in screen **S4.2.6 INmax1** i.e 20mA for a 4-20mA input.
- Set the maximum engineering units of the pressure transducer when it outputs the maximum signal level in screen **S4.2.7 Smax1** e.g 1000kPa for 20mA input.

TYPICAL CONFIGURATIONS SD700

G5 RATES ACC/DEC

- Adjust the acceleration rate in screen **G5.1 ACC1** and deceleration rate in screen **G5.2 DECEL1** to approximately 20%/sec so they won't interfere with the reaction time of the PID. If the acceleration and deceleration rates are too low then they will over ride the reaction time of the PID and the system may not react as required. It is also imperative to set the acceleration and deceleration rates so that the pump will accelerate in a minimum time to the minimum permissible pump speed according to pump manufacturers recommendations.

G8 OUTPUTS

- Program output relay 1 for the control to "JOCKEY PUMP" in screen **G8.1.1 SEL RELAY 1** to option 29 "JOCKEY PUMP".

G10 LIMITS

- Typically it is undesirable to run a pump backwards at any stage once the system is commissioned. To prevent this from happening, set screen **G10.1 MIN SP1** Minimum Speed to +0.00%. This will prevent the drive from outputting a negative speed reference to the motor. It may be a system requirement to set the minimum speed above +0.00% to prevent the pump from running too slow e.g. submersible pumps are usually required to run above a minimum speed of 30-35Hz (60-70% speed). Check with the pump manufacturer as to recommended minimum speeds.

Note: It may be more desirable to adjust this limit after having undertaken rotation checks on the motor and pump. Once the final direction has been determined set screen **G10.11 INVERSION?** To N(o) to prevent accidental reverse operation of the pump.

- Sometimes within a pumping system it is possible to have very high flow levels which may result in an overload of the motor. To prevent the motor from overloading and possibly tripping on F25 MTR O/L adjust the current limit **G10.5 I LIMIT** to equal or less than the motor rated current. The drive will then limit the current flowing to the motor to below this level by reducing the motor speed.

G25 PUMP

Screen group **G25 PUMP** is the main screen group where the pump control functionality is set up.

- Factory default for the PID feedback signal is analogue input 2. Because the pressure transducer is connected to analogue input 1 it is important to change the feedback reference in screen **S25.2.3 PID FBK** to AI1 before setting any other screens in **G25 PUMP** group.
- Screen **S25.1.1 CONTROL MODE** allows for the selection of automatic pump control or for manual control. When in automatic pump control (PUMP) all start/stop conditions and running conditions are governed by the values set in screen group **G25 PUMP** (once the Pump Start/Stp input is closed). When in manual mode (MANUAL) the drive responds to the keyboard start stop buttons and will run from the speed source selected in screen **S25.1.2 MAN REF1**. Usually this is programmed as LOCAL meaning the SD700 will run at the speed entered into **S25.1.3 MAN SPD**. This is useful for undertaking initial rotational checks etc before setting the system into automatic pump control.

- When the auto/off/manual switch is switched to “manual” (T3 closed), the SD700 will run from the speed source selected in screen **S25.1.2 MAN REF1**. Typically this is programmed as LOCAL meaning the SD700 will run at the speed entered into screen **S25.1.3 MAN SPD**.
- Set the speed the pump will run at when in a manual mode in screen **S25.1.3 MAN SPD**.
- Set the required system setpoint pressure in screen **S25.1.5 SETPT1**. The pressure setpoint will be in the units selected in analogue input 1 (provided the PID feedback signal has first been set to AI1).

- Screen **S25.2.1 PID SETP** sets the PID reference source. This screen is set to LOCAL (relates to the value set in screen **S25.1.5 SETPT1**) as default.
- Set the PID performance in screens **S25.2.4 PID Kc** to **S25.2.5 PID Dt**. Refer to description below for a guide to PID set up.

- Set screen **S25.3.1 LP Pon** to the “wake up” pressure that will command the VSD to start after a period of no demand. This is a differential value i.e the actual wakeup value = setpoint – LP Pon e.g setpoint of 500KPa, LP Pon=200Kpa, then actual wakeup is 500-200 = 300KPa.
- Set screen **S25.4.1 LP T SLP** to the required delay time before the VSD goes to “sleep” i.e the VSD must run below speed set in **S25.4.2 SLPspd1** for longer than the value set in **S25.4.1 LP T SLP** before it goes to “sleep”.
- Set screen **S25.4.2 SLPspd1** to the “sleep” speed level (in %) that the VSD will reduce to under a period of no demand.

- Set screen **S25.6.1 PAUSE/DEL** to the required pause delay. The pause delay is the time the SD700 waits before restarting after having stopped on High Pressure pause, Cavitation pause, or No Flow switch pause.
- Enable low pressure protection by setting screen **S25.6.7 ENA LO PRESS** to Y(es)
- Set the low pressure trip level in screen **S25.6.9 LO PRE**. This pressure is read from the pressure transducer signal.
- Set the low pressure trip delay time in screen **S25.6.10 LOp DLY**. Once the pressure drops below the value set in screen **S25.6.9** for longer than the time set in this screen the SD700 will trip on F65 “Low Pressure”.
- Set the high pressure fault level in screen **S25.6.13 HIpre**. This pressure is read from the pressure transducer signal.
- Set the high pressure trip delay time in screen **S25.6.14 HIpr DLY**. Once the high pressure level set in screen **S25.6.13 HIpre** is exceeded for the time value set in this screen the SD700 will stop and PAUSE for the time set in **S25.6.1 PAUSE/DEL** before restarting. If it is more desirable to have the SD700 fault on F66 “High Pressure” then set screen **S25.6.12 HIpr Mo** to FAULT.

Note: The high pressure switch connected to digital input 2 (T3) is an instantaneous trip and works independently to the above screens.

TYPICAL CONFIGURATIONS SD700

This pump macro has a function that allows for the gentle filling of an empty pipe. Once the VSD determines that the pipe is full it automatically switches to PID setpoint ramp. The PID setpoint is ramped up from the present level to the setpoint level (**S25.1.5 SETPT1**). This ramp prevents a large error being applied to the PID. Adjust the PID setpoint ramp so that the ramp rate is as close as possible to the pressure feedback rise rate. This can be observed in one of the Pump Macro Visualisation screens.

- Set the fixed speed the drive will run at when filling an empty pipe in screen **S25.7.2 FILL SP**
- Set the pressure level that is deemed to be a full pipe in screen **S25.7.3 FILL P**
- Set the maximum time the VSD is to run in pipe fill mode in screen **S25.7.4 FILL TIM**
- Set the PID setpoint ramp rate in screen **S25.7.5 STP RA**. This is in the engineering units selected in analogue input 1 per second. Typically this value is very low e.g <1.0kPa/sec

During periods of very low demand (stock water, tank filling, house water etc) the jockey pump will start to meet this demand. This pump will only start if the main SD700 is “sleeping”. The control of the output relay already programmed as “Jockey Pump” is determined by the values programmed into screens S25.9.7 – S25.9.9.

- Set the pressure that main line must drop down to start the jockey pump in **S25.9.7 JPon P**. Once the pressure drops to this level the output relay configured as “Jockey Pump” will switch on after the delay set in **S25.9.8 JPon DLY**.
- Set the delay time for switching the jockey pump on in **S25.9.8 JPon DLY**
- Set the pressure in screen **S25.9.9 JPof P** that main line must reach again to stop the jockey pump.

Note: If the mainline pressure continues to drop even with the jockey pump on and the “wake up” pressure is reached, the main pump will start and the jockey pump will be automatically stopped.

VISUALISATION

Lines two and three of the SD700 display are termed as Visualisation screens. These two screens can be set to display a number of motor, VSD, external I/O, internal, basic adjustments and pump macro variables. By setting these lines to Pump Macro variables it is possible to display the reference and feedback pressures and the status of the pump system e.g PIPE FILLING for pipe fill mode, SETPOINT RAMP for PID setpoint ramp etc.

4. – Notes for easy commissioning

Once the SD700 has been programmed it is then possible to undertake a few checks before running the system in fully automatic pump mode.

- Set screen **S25.1.1 CONTROL MODE** to “MANUAL”
- Set the desired manual speed in screen **S25.1.3 MAN SPD**. Ensure this speed is above the recommended minimum operational speed for the pump.
- Start the SD700 from the keypad and make sure the pump is rotating in the correct direction. If it is a surface pump then it is simply a case of visually checking rotation. If it is a submersible pump then it may be necessary to run the pump in both directions to gauge water delivery.

Note: To undertake reverse operation it is necessary to have the minimum speed limit screen set in a negative direction (screen **G10.1 MIN SP1**) and to permit reverse operation in screen **G10.11 INVERSION = Y**. Once the correction rotation has been determined, set these screens back to prevent reverse operation.

- Set screen **S25.1.1 CONTROL MODE** to “PUMP”.
- Close the PMP START/STP input

The drive will now run in PIPE FILL mode provided the system permissives are met. Once the pressure has reached the PIPE FILL pressure or the maximum PIPE FILL TIME has expired the VSD will enter PID SETPOINT RAMP and will increase in speed until the setpoint pressure is met.

At this stage the VSD will change into full PID control and will pressure regulate to keep the system pressure at the system pressure setpoint. This is the stage where it maybe necessary to tune the PID. Refer to section 5 below for hints on how to tune the PID for stable pressure control.

If all the water outlets are closed while the VSD is running then the VSD will ramp down under PID control until it reaches the SLEEP speed at which point the VSD will turn off after the delay time and enter “SLEEP MODE”.

Note: SLEEP mode will only work if the hydraulic system is fitted with a non return valve, permitting the trapping of water under pressure within the pipe work. The pressure transducer must be mounted on the outlet side of the non return valve.

Once in “SLEEP MODE” the VSD continues to monitor the pressure feedback from the transducer. Should a water outlet be opened then the system pressure will drop, and once it drops to the “WAKE” pressure level the drive will start and PID SETPOINT RAMP back to the operational setpoint.

It is necessary to experiment with the “SLEEP” and “WAKE” levels in conjunction with the PID tuning to ensure a stable system.

5.- PID tuning guide

- Tuning the PID is achieved by making adjustments to parameters to **S25.2.4 PID Kc**, **S25.2.5 PID It** and **S25.2.6 PID Dt**. These parameters allow tuning of the following:
- **S25.2.4 PID Kc** Gain: Adjustment to the proportional gain (Kc) of the PID is made by altering the value entered into this screen. As the proportional gain is increased the system responds more rapidly to changes around the setpoint. This results in the proportional error being smaller as the gain value is increased with the trade off being the system becomes less stable. PID Kc Gain value is set as a percentage value of the PID controller output versus the actual error value. Too higher value of proportional gain results in the PID overshooting and oscillating.

TYPICAL CONFIGURATIONS SD700

- **S25.2.5 PID It** time: Adjustment to the integral gain (It) of the PID is made by altering the value entered into this screen. Whilst correct tuning of the proportional component of the PID loop can substantially reduce error it can never completely eliminate the error to a zero level. The It component of the PID loop can help reduce the system error to zero by adding an integral term to the control function. PID It gain value is set as the time in seconds that it takes for the PID controller output to reach 100% output when there is 100% error. Too higher value of integral gain (a low number of seconds) results in the PID overshooting and oscillating.
- **S25.2.6 PID Dt** time: Adjustment to the differential gain (Dt) of the PID is made by altering the value entered into this screen. Adding a differential component to the PID loop is intended to improve stability, reduce overshoot and improve response speed by anticipating error. In the majority of pumping applications the Dt component is set to zero as this component is not required. PID Dt gain is set as a time in seconds. The time value set is effectively a dampening period.

A simple method for tuning PID control loops which is effective for the majority of pumping applications is:

- Set screens **G5.1 ACC1** and **G5.2 DECEL1** to high rates (e.g. >20%/sec) to ensure that they do not interfere with PID response time when tuning
- Set the system so there can be a minimal flow e.g. partly open a valve
- Start the SD700 by closing the PMP START/STP input and let the SD700 ramp up until it enters full PID control i.e. completed Pipe Fill and PID Setpoint Ramp.
- Increase the value in screen **S25.2.4 PID Kc** (PID Proportional Gain). Continue increasing this value until oscillation of the pressure feedback signal (viewed in the Visualisation screens) occurs. Adjust the value in screen **S25.2.4 PID Kc** to about 40% of this value.
- With the pump still operating and the new value entered into screen **S25.2.4 PID Kc**, decrease the value in screen **S25.2.5 PID It** (PID Integral time) until oscillation of the pressure feedback signal occurs. Adjust the value in screen **S25.2.5 PID It** to about 150% of this value.
- Leave the value in **S25.2.6 PID Dt** (PID Derivative time) at 0.0 sec.

Note: Screen group **G6 P.I.D** is not valid in Pump Macro control.

Use the figures below to assist with setting the various pressure and speed levels for the pump system.

PRESSURE

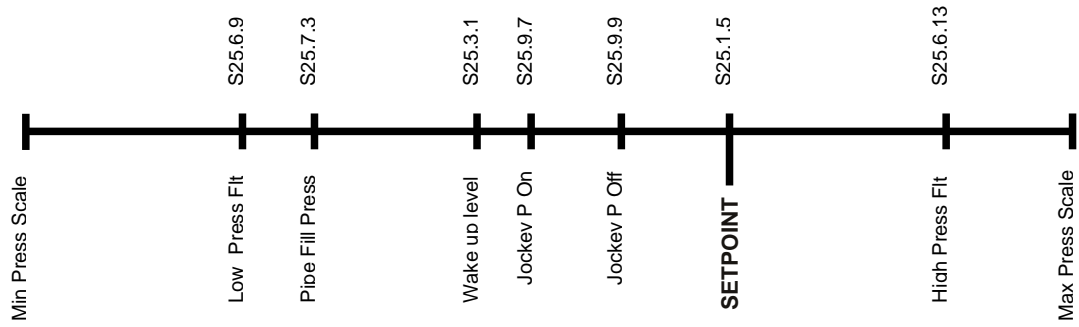

SPEED

