



General Application Note DDLM020 Rev A

GENERAL APPLICATION NOTE

EMC Installation Guide for SD250 and SD450 series

Created: A J Buckley
Position: Engineering Manager
Date: 06/07/09

Reviewed: Mark Duncan
Position: S & M Director
Date: 18/07/09

1. Background EMC information

This guide provides the installer with sufficient information to ensure correct installation of the SD250 and SD450 series so that they meet the electromagnetic compatibility (EMC) levels to which they have been tested and certified to. Correct EMC installation will minimize the likelihood of faulty operation or radio frequency interference (RFI) with surrounding equipment.

In New Zealand variable speed drives (VSDs) must be marked with “C-tick” in order to verify compliance with the relevant standard, IEC 61800-3 (2004): “Adjustable Speed Electrical Power Drive Systems”. Part 3: “EMC Requirements and Specific Test Methods”. The “C-tick” marking is managed by the Ministry of Economic Development’s Radio Spectrum Management group (RSM). Both the SD250 and SD450 series are marked “C-Tick”.

2. The Electrical Environment

IEC 61800-3 defines two types of electrical environment. Select the correct installation environment for which you intend to install either the SD250 series or SD450 series based on the following definitions:

- First environment

The First Environment includes domestic premises. It also includes establishments directly connected without an intermediate transformer to a low-voltage power supply network which supplies buildings used for domestic purposes such as shopping malls, cinemas, hospitals...

- Second environment

Second Environment includes all establishments other than those directly connected to a low-voltage power supply network which supplies buildings used for domestic purposes. E.g. factories and those other premises supplied by their own dedicated transformer.

Figure 1 - Environments

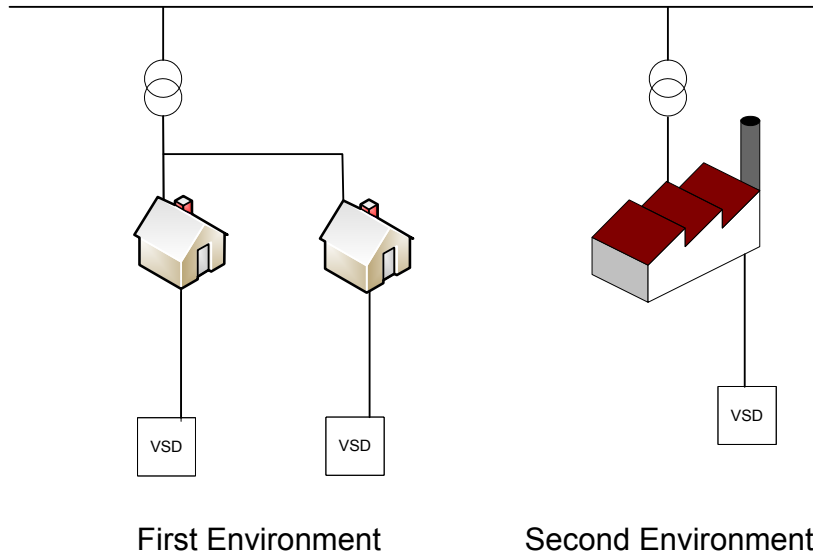

3. SD250 Series Power Wiring

General Requirements for Domestic and Industrial Environments

Motor cables must be four core, symmetrical with an overall screen providing greater than 90% coverage. A proper VSD screened cable is preferable. Conduits or metal ducting can be used for part of the shielding length provided that this is continuous. Maximum motor cable length is not to exceed 50m.

Figure 2 - Typical Gland Arrangement at Motor

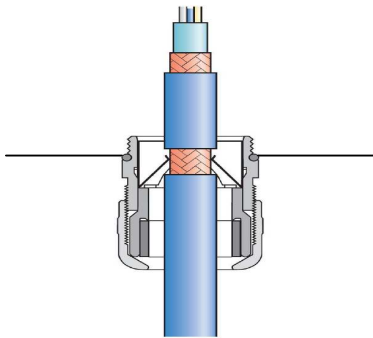

Note - RFI screen is not usually terminated at the earth terminal of the motor when a proper VSD cable gland is used.

A screened cable gland suitably designed and sized for the screened cable type used should be fitted at the motor end. **Do not** wind the screen into a "pigtail" and terminate under the earth terminal within the motor terminal box.

When housing the SD250 within an MCC ensure that the screen of the motor cable is terminated to the SD250 earth terminal and not the MCC main earth bar. When housing the SD250 in its own metal enclosure, the enclosure can be used as part of the overall screen. In this circumstance a screened cable gland suitably designed and sized for the screened cable type used should be fitted to the enclosure. A braided earth conductor should then be connected from the gland to the main earth terminal on the SD250. NB. If the enclosure is painted, remove paint around the gland to ensure good contact is made between the gland and the metal of the enclosure.

Figure 3 - Showing typical arrangement when SD250 is within MCC or Enclosure.

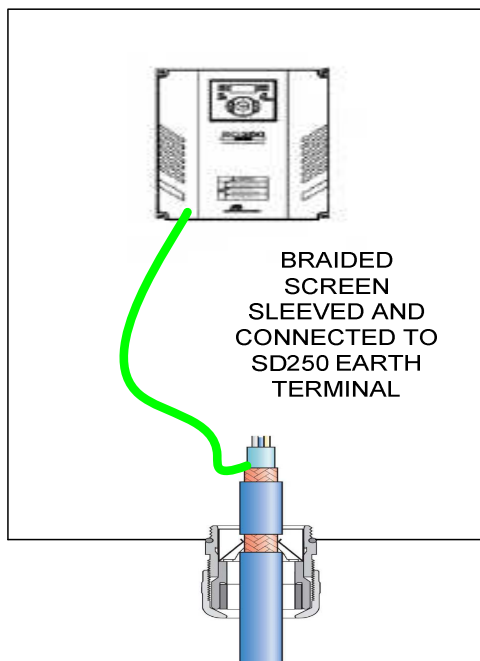

Motor earth must be connected to the drive earth terminal and not the installation's ground. It is recommended that the cross section of the earth conductor should be greater than or equal to the phase conductor.

Installation ground must be connected to the SD250 earth terminal.

Do not install the motor cables parallel to the main input supply cables.

Additional Requirements for Second Environment Installation - Industrial

The SD250 series is fitted with radio frequency interference (RFI) filters as standard. External supply side RFI filters are not required when the drive is installed in an industrial environment. Shielded mains supply cables are not necessary to meet EMC requirements.

When direct wall mounting the SD250 with the optional conduit box, use a suitably designed and sized screened cable gland when terminating the motor cable. Ensure paint is removed around the cable gland entry to provide sufficient contact between gland and metal of the conduit box.

Figure 4 – SD250 Fitted with optional conduit box

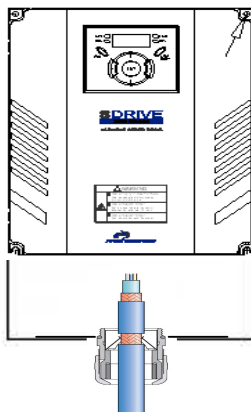

Note - RFI screen is not usually terminated at the earth terminal of the SD250 when a proper VSD cable gland is used.

Additional Requirements for First Environment Installation – Domestic

When installing the SD250 series into a domestic environment it is necessary to fit an additional RFI filter into the main supply side. This filter can be foot mounted directly underneath or directly alongside the SD250. It is also necessary to fit a ferrite core into the motor cable on the output of the SD250.

Mount the RFI filter as close as possible to the incoming mains supply of the wiring enclosure, usually directly after the circuit breaker or supply switch.

Care should be taken to remove paint from around the mounting holes and face area of the gear plate to ensure the best possible earthing of the RFI filter.

Connect the mains supply to the filter terminals marked LINE. Connect the earth conductor to the RFI filter earth stud. Connect the filter terminal marked LOAD to the main input of the SD250 using as short a cable lengths as possible.

Securely connect the RFI filter earth stud to the SD250 earth terminal and the enclosure earth (including the gear plate)

Fit a ferrite core into the SD250 output cable (motor cable). Pass the three phase conductors of the motor cable through the center of the ferrite core twice. Terminate the motor cable as previously described.

NOTE: IT IS IMPORTANT TO KEEP CABLE LENGTHS AS SHORT AS POSSIBLE.

Never install the RFI filter in the output of the SD250 as this could damage the drive.

Do not use an RFI filter when connected to a floating earth installation.

Figure 5 – SD250 with First Environment RFI Filter (Footprint or External)

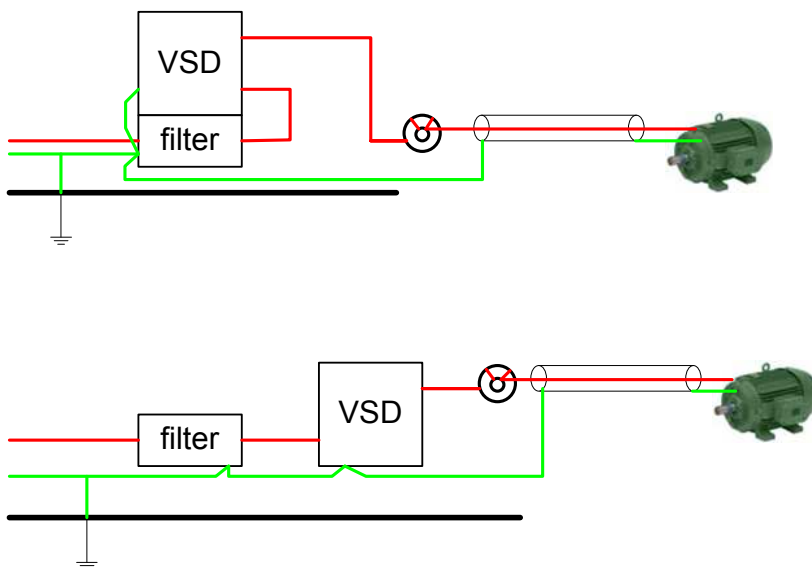

4. SD250 Control Wiring

Always use screened cables for the control wiring connected to the SD250. Screened cables comprising of twisted pairs is best for noise rejection.

Segregate control wiring from both power supply cables and motor cables. Use separate trunking or cable tray spaced a minimum of 300mm apart.

Where control wiring must cross power cables ensure this is done at 90 degrees to prevent inducing noise or an EMF into the control wires.

Terminate the screen of the control wiring to the ground of the SD250.

Figure 6 – Control Wiring

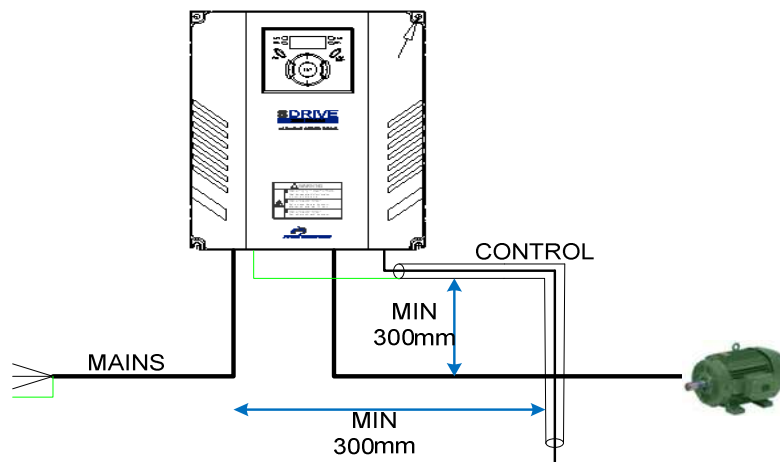

5. SD450 Power Wiring

General Requirements for Domestic and Industrial Environments

Motor cables must be three core, symmetrical with an overall screen providing greater than 90% coverage. A proper VSD screened cable is preferable. Conduits or metal ducting can be used for part of the shielding length provided that this is continuous. Maximum motor cable length is not to exceed 50m for SD45008 –SD45045 and 100m for SD45060 – SD45150.

Figure 7 - Typical Glanding Arrangement at Motor

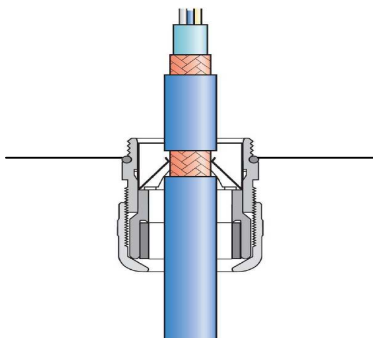

Note - RFI screen is not usually terminated at the earth terminal of the motor when a proper VSD cable gland is used.

A screened cable gland suitably designed and sized for the screened cable type used should be fitted at the motor end. **Do not** wind the screen into a “pigtail” and terminate under the earth terminal within the motor terminal box.

When housing the SD450 within an MCC ensure that the screen of the motor cable is terminated to the SD450 earth terminal and not the MCC main earth bar. When housing the SD450 in its own metal enclosure, the enclosure can be used as part of the overall screen. In this circumstance a screened cable gland suitably designed and sized for the screened cable type used should be fitted to the enclosure. An earth conductor should then be connected from the gland to the main earth terminal on the SD450. NB. If the enclosure is painted, remove paint around the gland to ensure good contact is made between the gland and the metal of the enclosure.

Figure 8 - Showing typical arrangement when SD450 is within MCC or Enclosure.

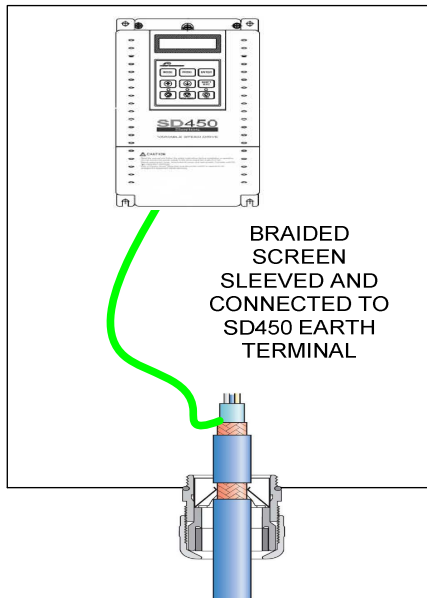

Motor earth must be connected to the drive earth terminal and not the installation's ground. It is recommended that the cross section of the earth conductor should be greater than or equal to the phase conductor.

Installation ground must be connected to the SD450 earth terminal.

Do not install the motor cables parallel to the main input supply cables.

Additional Requirements for Second Environment Installation - Industrial

The SD450 series is fitted with radio frequency interference (RFI) filters as standard. External supply side RFI filters are not required when the drive is installed in an industrial environment. Shielded mains supply cables are not necessary to meet EMC requirements.

When direct wall mounting the SD450 use a suitably designed and sized screened cable gland when terminating the motor cable at the drive end.

Figure 9 – Glanding at SD450

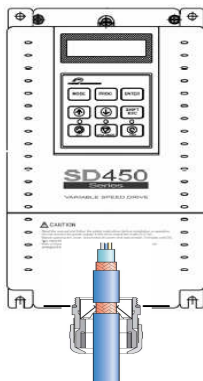

Note - RFI screen is not usually terminated at the earth terminal of the SD450 when a proper VSD cable gland is used.

Additional Requirements for First Environment Installation – Domestic

When installing the SD450 series into a domestic environment it is necessary to fit an additional RFI filter into the main supply side. For models SD45008 – SD45045 this filter can be foot mounted directly underneath or directly alongside the SD450. For models SD45060 – SD45150 this filter should be mounted directly alongside the SD450. It is also necessary to fit a ferrite core into the motor cable on the output of the SD450.

Mount the RFI filter as close as possible to the incoming mains supply of the wiring enclosure, usually directly after the circuit breaker or supply switch.

Care should be taken to remove paint from around the mounting holes and face area of the gear plate to ensure the best possible earthing of the RFI filter.

Connect the mains supply to the filter terminals marked LINE. Connect the earth conductor to the RFI filter earth stud. Connect the filter terminal marked LOAD to the main input of the SD450 using as short a cable lengths as possible.

Securely connect the RFI filter earth stud to the SD450 earth terminal and the enclosure earth (including the gear plate)

Fit a ferrite core into the SD450 output cable (motor cable). Pass the three phase conductors of the motor cable through the center of the ferrite core twice. Terminate the motor cable as previously described.

NOTE: IT IS IMPORTANT TO KEEP CABLE LENGTHS AS SHORT AS POSSIBLE.

Never install the RFI filter in the output of the SD450 as this could damage the drive.

Do not use an RFI filter when connected to a floating earth installation.

Figure 10– SD450 with First Environment RFI Filter (Footprint or External)

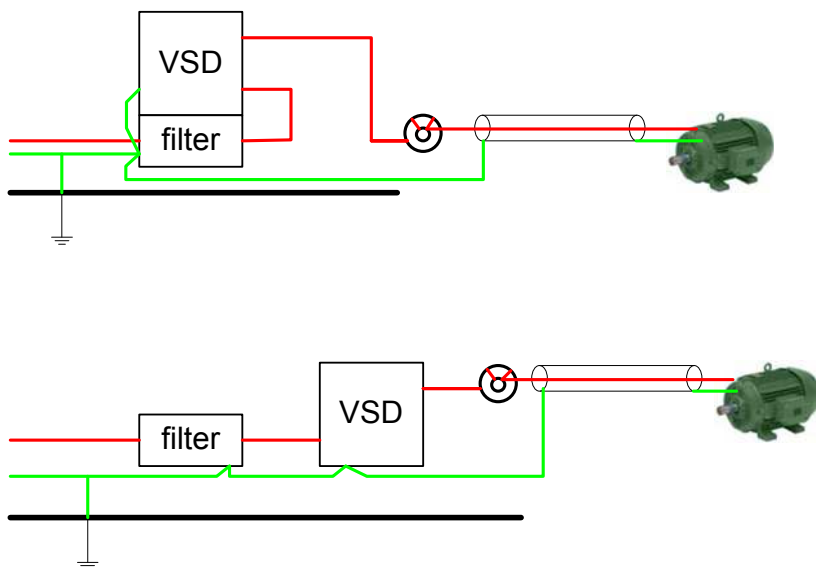

6. SD450 Control Wiring

Always use screened cables for the control wiring connected to the SD450. Screened cables comprising of twisted pairs is best for noise rejection.

Segregate control wiring from both power supply cables and motor cables. Use separate trunking or cable tray spaced a minimum of 300mm apart.

Where control wiring must cross power cables ensure this is done at 90 degrees to prevent inducing noise or an EMF into the control wires.

Terminate the screen of the control wiring to the ground of the SD450.

Figure 11 – Control Wiring

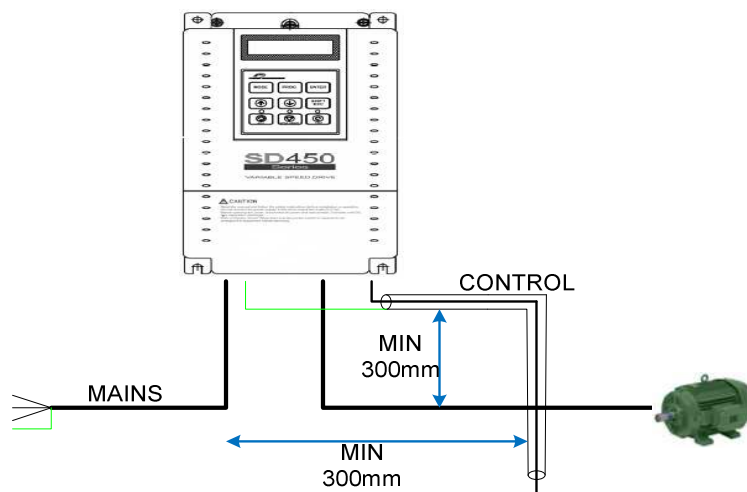

Note: it is the responsibility of the user to evaluate the accuracy, completeness or usefulness of any content in this paper. Neither Drive Dynamics nor its affiliates make any representations or warranties regarding the content contained in this paper. Drive Dynamics nor its affiliates will be liable to any user or anyone else for any inaccuracy, error or omission, regardless of cause, or for any damages resulting from any use reliance or reference to the content of this paper.